

# EIDOS *pro*



**èidos** s. m. [traslitt. del gr. εἶδος «aspetto, forma»].  
Termine con cui Platone designa l'idea, Aristotele la forma;  
è stato ripreso dal filosofo E. Husserl (1859-1938)  
per designare l'essenza oggetto d'intuizione.

**èidos** s. m. [translitt. of the gr. εἶδος «appearance, form»].  
Term with which Plato designates the idea, Aristotle the form;  
it was taken up by the philosopher E. Husserl (1859-1938)  
to designate the essence object of intuition.

NEWFORM

# EIDOS *pro*

Una collezione versatile e dal design raffinato, frutto di un lavoro intellettuale e concettuale concretizzato dallo straordinario 'saper fare' italiano.

La linea Eidos pro è basata sull'idea della connessione degli elementi ed è stata disegnata per andare incontro alle esigenze degli uffici operativi in modo flessibile.

Il design essenziale soddisfa il bisogno di funzionalità e solidità, garantendo così soluzioni dalla efficienza ottimale e permettendo la creazione di una vasta gamma di combinazioni per personalizzare in modo sartoriale sia lo spazio lavorativo che quello domestico.

A versatile collection with a refined design, the result of intellectual and conceptual work realized by the extraordinary Italian 'know-how'.

The Eidos pro collection is based on the idea of connecting elements and was designed to meet the needs of operative offices in a flexible way.

The essential design meets the need for functionality and solidity, ensuring optimal efficiency solutions and allowing the creation of a wide range of combinations to customize both the working and the domestic space.

Una colección versátil y de diseño refinado, fruto de un trabajo intelectual y conceptual concretado por el extraordinario 'saber hacer' italiano.

La línea Eidos pro se basa en la idea de la conexión de los elementos y se diseñó para encontrar la necesidad de oficinas operativas de forma flexible.

El diseño esencial y agradable satisface la necesidad de funcionalidad y solidez, garantizando así soluciones de eficiencia óptima y permitiendo la creación de una amplia gama de combinaciones para personalizar de manera sartorial tanto el espacio laboral como el doméstico.

Une collection polyvalente au design raffiné, fruit d'un travail intellectuel et conceptuel concrétisé par l'extraordinaire 'savoir-faire' italien.

La gamme Eidos pro est basée sur l'idée de la connexion des éléments et a été conçue pour répondre aux besoins des bureaux opérationnels de manière flexible.

Le design essentiel satisfait les nécessités de fonctionnalité et solidité, garantissant ainsi des solutions efficaces et permettant la création d'une large gamme de combinaisons, pour personnaliser l'espace de travail et domestique.



# EIDOS *pro*

## — 01

---

Ambienti luminosi e rigeneranti.  
Le spazialità vengono sapientemente identificate e condivise dal sistema libreria senza rinuncia della privacy, mediante l'utilizzo di arredi per l'archiviazione che non limitano la visibilità.

---

Bright and regenerating environments.  
The spaces are widely identified and shared by the bookcase system without giving up their privacy and using storage cabinets that do not limit visibility.

Ambientes luminosos y regeneradores.  
Los espacios son sabiamente identificables y están compartidos por el sistema librería sin renunciar a la privacidad, mediante el uso de mobiliario de archivo que no limite la visibilidad.

Environnements lumineux et régénérateurs.  
Les espaces sont intelligemment identifiés et partagés par le système bibliothèque, sans renoncer à la vie privée, par l'utilisation de meubles d'archivage qui ne limitent pas la visibilité.













# EIDOS *pro*

## — O2

---

Dinamicità, forza e carica vitale.

Le postazioni di lavoro diventano espressione mutevole degli spazi attraverso la sapiente gestione di strutture portanti e piani lavoro, per dare vita alle diverse esigenze del quotidiano.

---

Dynamism, strength, and vital charge.

Workstations become a changing expression of spaces through the wise positioning of load-bearing structures and worktops, to give life to the different needs of everyday life.

Dinamismo, fuerza y carga vital.

Las estaciones de trabajo se convierten en expresión cambiante de los espacios a través de la sabia gestión de estructuras portantes y superficies de trabajo, para dar vida a las diferentes necesidades de la vida cotidiana.

Dynamisme, force et charge vitale.

Les postes de travail deviennent expression en évolution des espaces à travers une gestion savante de structures portantes et plans de travail, pour donner vie aux différentes exigences du quotidien.













# EIDOS *pro* — 03

---

Pianificazione, operatività, confronto.  
I concetti chiave del successo lavorativo vengono ritmati e armonizzati grazie all'adozione di arredi pensati per supportare ogni attività lavorativa, offrendo le migliori condizioni di comfort e benessere.

---

Planning, efficiency, comparison.  
The key concepts of job success are rhythmized and harmonized thanks to the selection of furnishings designed to support every work activity, offering the best conditions of comfort and well-being.

Planificación, operatividad, comparación.  
Los conceptos clave del éxito laboral están ritmatizados y armonizados gracias a la adopción de muebles diseñados para apoyar cualquier actividad laboral.

Planification, opérativité, partage.  
Les concepts clés de la réussite professionnelle sont rythmés et harmonisés grâce au choix de meubles conçus pour soutenir chaque activité professionnelle, offrant les meilleures conditions de confort et de bien-être.













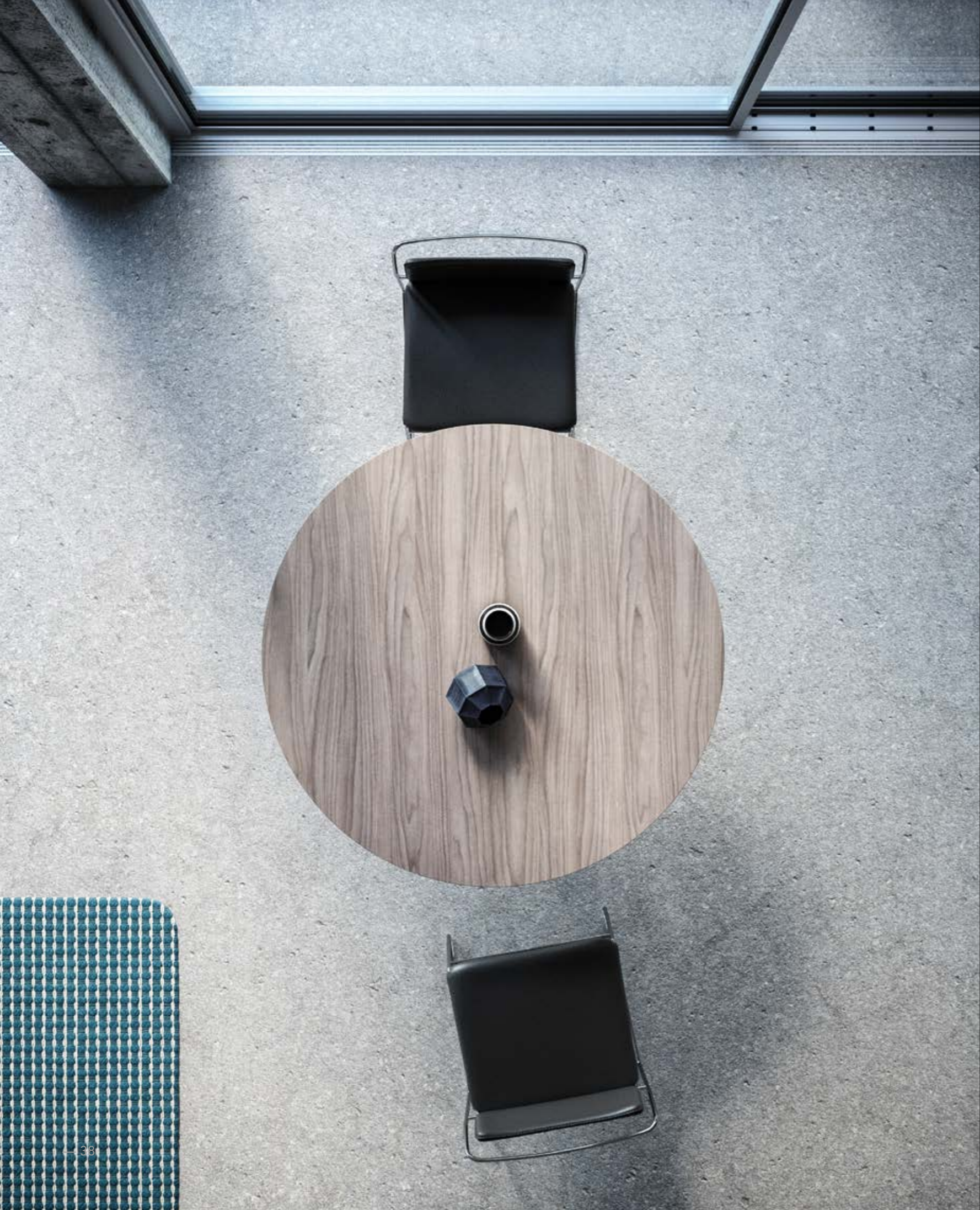

# EIDOS *pro*

## — O4

---

Illuminazione, connessione, organizzazione.  
L'adozione di pareti accessoriabili tra le postazioni ricreano momenti di intimità lavorativa senza tralasciare l'importanza dell'intesa lavorativa resa possibile attraverso l'adozione di "pannelli vetrati".

---

Lighting, connection, organization.  
The use of equippable partitions between the workstations recreate moments of work intimacy not leaving out the importance of working agreement made possible through the use of "glass panels".

Iluminación, conexión, organización.  
El uso de paredes divisorias equipables entre las estaciones recrean momentos de intimidad laboral sin olvidar la importancia de las relaciones de trabajo que se consiguen mediante el uso de "paneles de vidrio".

Éclairage, connexion, organisation.  
L'adoption de cloisons à équiper entre les postes de travail recréent des moments d'intimité professionnelle sans négliger l'importance des relations professionnelles rendues possibles par l'adoption de "panneaux vitrés".















# EIDOS *pro*

## — O5

---

Linearità geometrica, purezza delle forme.  
L'organizzazione delle grandi spazialità è resa possibile grazie all'utilizzo di elementi sobri e discreti studiati per rendere confortevole il lavoro di tutti i giorni grazie anche agli elementi per l'archiviazione che segnano e ordinano gli ambienti.

---

Geometric linearity, purity of forms.  
The organization of large spaces is made possible thanks to the use of sober and discreet elements designed to make every day work comfortable thanks also to the storage units that mark and order environments.

Linealidad geométrica, pureza de las formas.  
La organización de los grandes espacios se consigue gracias al uso de elementos sobrios y discretos diseñados para que el trabajo de todos los días sea más cómodo gracias también a los elementos de almacenamiento que marcan y ordenan los ambientes.

Linéarité géométrique, pureté des formes.  
L'organisation des grands espaces est rendue possible grâce à l'utilisation d'éléments sobres et discrets conçus pour rendre le travail quotidien confortable grâce aux éléments d'archivage qui marquent et mettent en ordre les pièces.





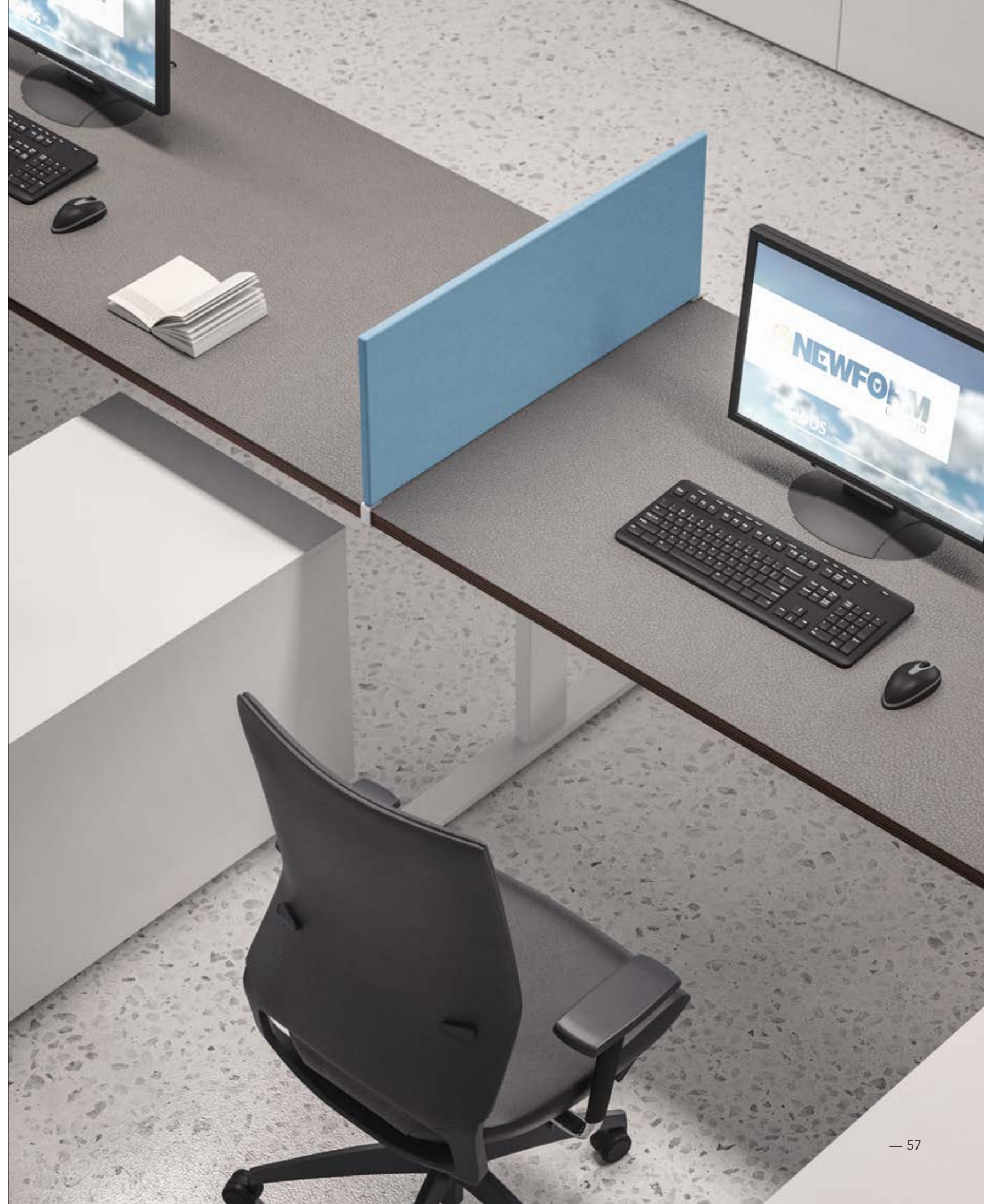











# EIDOS *pro* — 06

---

Spazio, luce, natura.

Il lavoro di tutti i giorni vive e sperimenta anche altri ambiti dell'operatività quotidiana grazie ad un arredo mirato per offrire la massima fruizione nei diversi utilizzi cui è destinato come le piccole isole di archiviazione intese come momento di spunto e rigenerazione per la mente.

---

Space, light, nature.

Everyday work also lives and experiences other areas of daily operation thanks to a targeted furniture able to offer maximum enjoyment in the different uses for which it is intended like the small storage islands considered as a moments of inspiration and regeneration for the mind.

Espacio, luz, naturaleza.

El trabajo de todos los días vive y experimenta también otros ámbitos de la operatividad diaria gracias a una decoración específica para ofrecer el máximo disfrute en los diferentes usos a los que está destinada como las pequeñas islas de almacenamiento concebidas como momento de inspiración y regeneración para la mente.

Espace, éclairage, nature.

Le travail de tous les jours vit et expérimente également d'autres domaines de l'activité quotidienne grâce à un mobilier ciblé pour offrir un maximum d'optimisation dans les différentes utilisations auxquelles il est destiné, comme les petites zones de stockage conçues comme un moment d'inspiration et de régénération pour l'esprit.

















# EIDOS *pro*

## — 07

---

Rigore, personalizzazione, relax.

La qualità della vita in ufficio è determinata anche dalla gestione e dall'organizzazione dello spazio.

Ogni complemento è pensato infatti per adattarsi alle più diverse esigenze e per garantire sempre la massima fruibilità di ogni ambiente permettendo così molteplici configurazioni delle postazioni lavorative grazie alle scrivanie mobili, fra cura della persona, applicazione di criteri di ergonomia sociale e flessibilità dei sistemi.

---

Rigour, customization, relax.

Quality of life in the office is also determined by the management and organization of the space. Each complement is, in fact, designed to adapt to the most different needs and to ensure always the maximum usability of every environment. In this way it allows multiple layouts of workstations thanks to the movable desks, providing personal care, the implementation of ergonomic concepts and system flexibility.

Rigor, personalización, relax. La calidad de vida en la oficina también está determinada por la gestión y la organización del espacio. Cada complemento está pensado para adaptarse a las más diferentes necesidades y para garantizar siempre el máximo disfrute de cualquier espacio permitiendo así múltiples configuraciones de los puestos de trabajo gracias a los escritorios móviles, ofreciendo cuidado personal, aplicación de criterios de ergonomía social y flexibilidad de los sistemas.

Rigueur, personnalisation, relax.

La qualité de la vie dans un bureau est déterminée aussi par la gestion de l'espace et l'organisation. Chaque complément est conçu en effet pour s'adapter aux exigences plus diverses et pour garantir toujours une utilisation optimale de chaque environnement, en permettant des configurations variées des postes de travail, grâce aux bureaux sur roulettes. Soin de la personne, application de critères ergonomiques, flexibilité des systèmes.











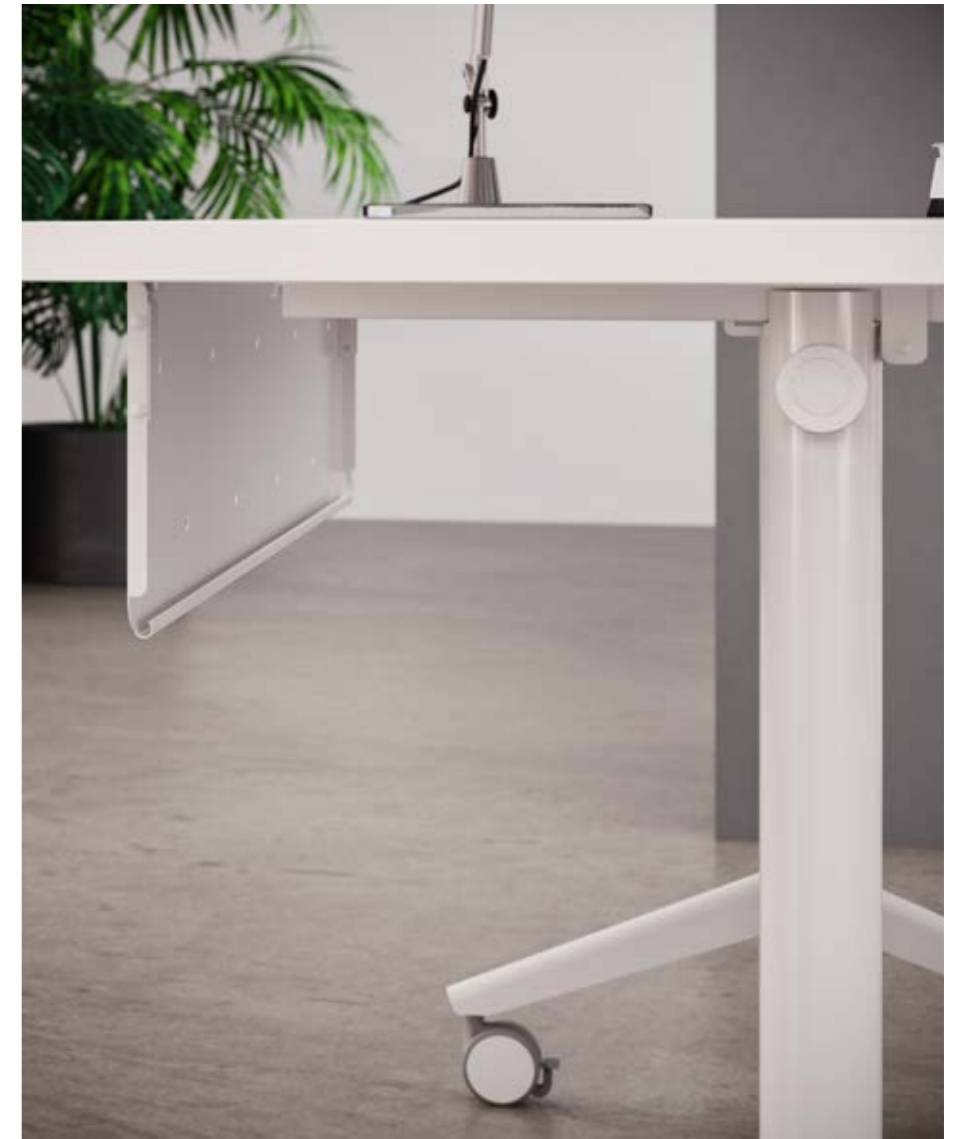





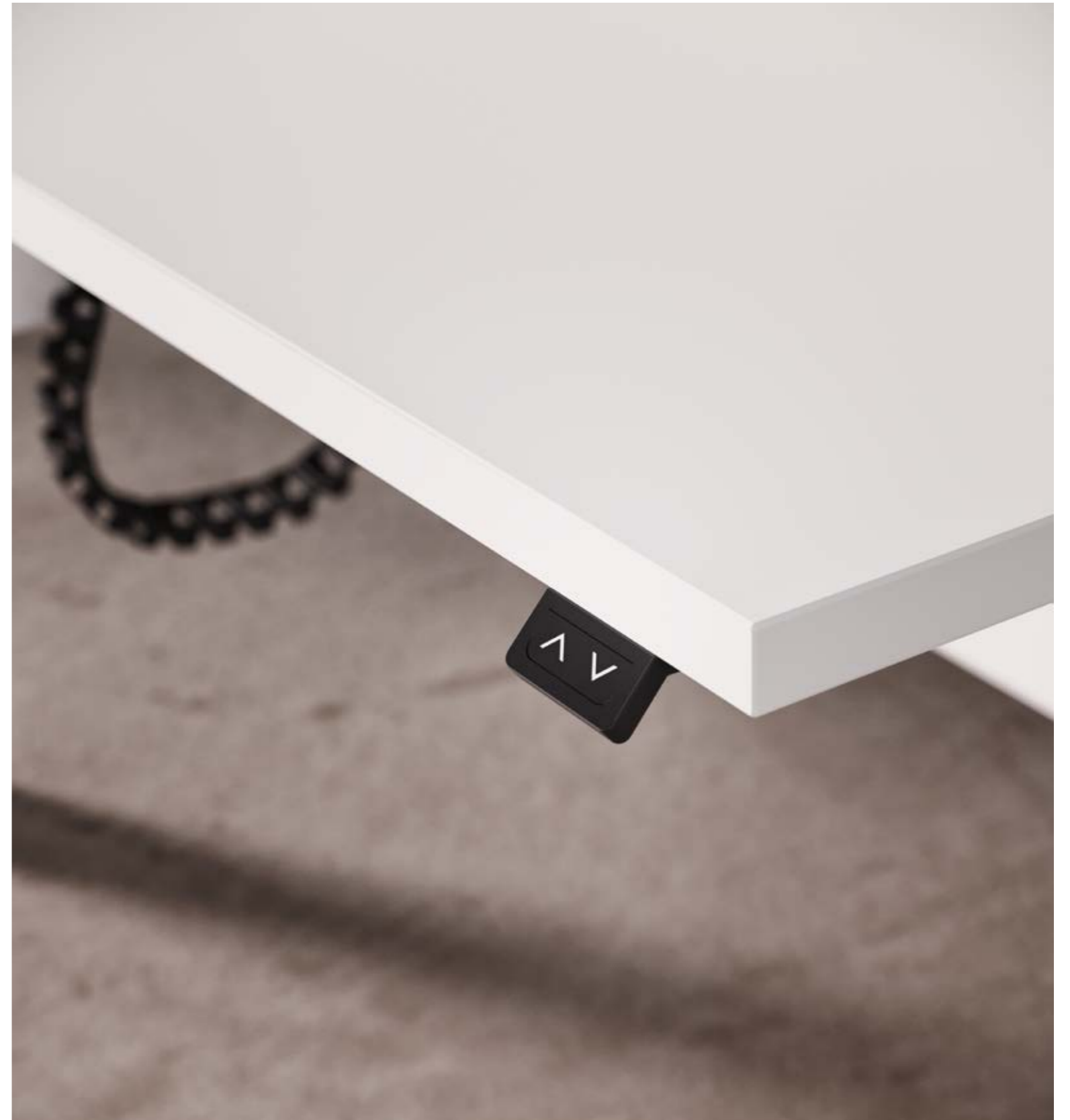



# EIDOS *pro*

## — 08

---

Tradizione, spazialità, cromie.

La memoria classica e tradizionale dell'ufficio è oggi rivisitata in chiave contemporanea nel rispetto delle regole di continuità e divenire nel tempo. Ricreare spazialità intime e raccolte secondo la dimensione dell'abitare domestico cui le finiture della serie ben si adattano, è oggi diventata necessità.

---

Tradition, spatiality, colours.

The classic and traditional office is now revisited in a contemporary key respecting the rules of continuity and becoming over time. Recreating private and intimate spaces according to the domestic setting where the finishes of the series are well suited, has become a necessity today.

Tradición, espacialidad, colores.

La memoria clásica y tradicional de la oficina se revisa hoy en clave contemporánea en el respeto de las reglas de continuidad y devenir en el tiempo. Recrear espacios íntimos y recogidos según el tamaño de la vivienda cuyos acabados de la serie encajan bien, se ha convertido en una necesidad.

Tradition, espace, couleurs.

La mémoire classique et traditionnelle du bureau est aujourd'hui revisitée dans un sens contemporain dans le respect des règles de continuité et devenir dans le temps. Recréer des espaces intimes et chaleureux à mesure d'environnement domestique dont les finitions de la série s'adaptent bien, est aujourd'hui devenue nécessité.







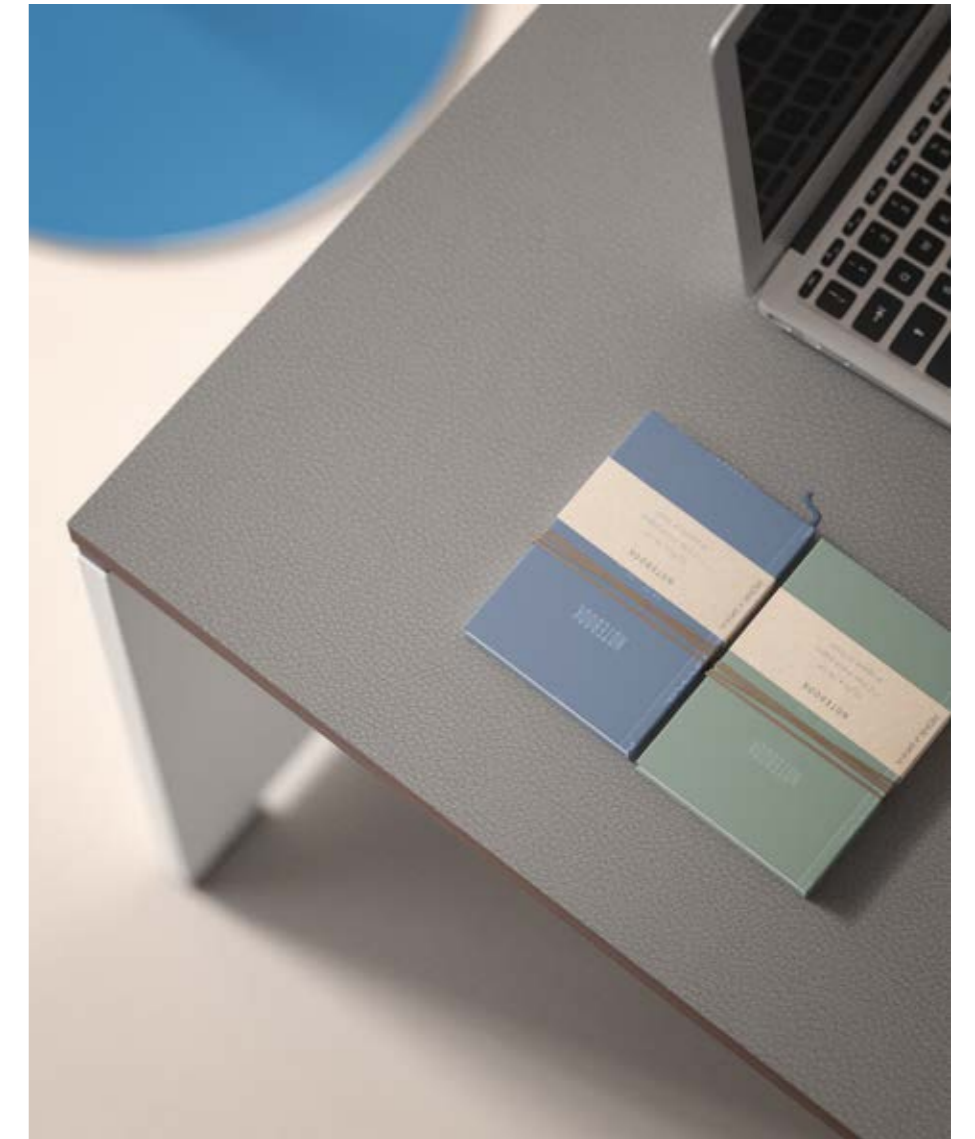







# EIDOS *pro*

## — 09

---

Dinamicità, personalizzazione.

L'ufficio oggi è sempre più accogliente in quanto inteso come abito tailor made nonchè mutevole. Le postazioni dunque sono cablate e adattive al fine di assecondare l'utilizzo del singolo; il tutto mediante l'utilizzo di strutture ad altezza selezionabile che seguono e nello stesso tempo anticipano le attuali normative che disciplinano il comfort lavorativo.

---

Dynamism, customization.

The office today is increasingly welcoming intended as a tailor made dress as well as changing. The workstations are therefore wired and adaptive in order to support the individual use of; all this through the use of structures at height selectable which follow and at the same time anticipate the current regulations governing working comfort.

Dinamismo, personalización.

La oficina es cada vez más acogedora entendida como traje hecho a medida o sea cambiante. Los puestos están cableados y adaptables con el fin de secundar el uso del individuo; todo mediante el uso de estructuras de altura seleccionable que siguen y al mismo tiempo anticipan las normas actuales que regulan el confort laboral.

Dynamisme, personnalisation.

Le bureau est de plus en plus confortable comme une robe sur mesure.

Les postes sont donc câblés et adaptatifs afin de faciliter l'utilisation de chaque utilisateur; le tout grâce à des structures à hauteur variable qui suivent et anticipent en même temps les réglementations actuelles régissant le confort de travail.













# EIDOS *pro*

## — 10

---

Colorata, eclettica, accattivante.

Hook, disegnata da Karim Rashid e vincitrice dell'Award Recipient C77DA - The Best of Design - è la soluzione ideale per organizzare al meglio tanto lo spazio ufficio quanto il lavoro. Caratterizzata da un design allo stesso tempo lineare ed estroso, è personalizzabile nelle finiture e nei colori offrendo una linea di arredi completamente modulari. Per avere a casa, come a lavoro, un tocco decisamente POP.

---

Colorful, eclectic, attractive.

Hook, designed by Karim Rashid and winner of the Award Recipient C77DA - The Best of Design - is the ideal solution to organize the office space as well as the work. Characterized by a design at the same time linear and whimsical, is customizable in finishes and colours offering a line of completely modular furniture. To give a decidedly pop twist to your home, as well as your office.

Colorida, ecléctica, artactiva.

Hook, diseñada por Karim Rashid y ganadora del Premio Recipient C77DA - The Best of Design - es la solución ideal para organizar mejor tanto el espacio de oficina como el trabajo. Caracterizada por un diseño a la vez lineal y extrovertido, es personalizable en acabados y colores ofreciendo una línea de muebles totalmente modulares. Para tener en casa, como en el trabajo, un toque definitivamente POP.

Colorée, éclectique, captivante.

Hook, conçue par Karim Rashid et bénéficiaire du prix Recipient C77DA - The Best of Design - est la solution idéale pour organiser au mieux l'espace bureau ainsi que le travail. Caractérisé par un design à la fois linéaire et extravagant, il est personnalisable en finitions et couleurs offrant une gamme de meubles entièrement modulables. Pour avoir à la maison, comme au travail, une touche carrément POP.











# EIDOS *pro*

## — 11

---

Aree dining nell'ufficio che guarda al futuro.

La collezione Eidos Evo propone elementi modulabili ideali per arredare anche gli spazi dedicati al relax come tavoli tondi, armadiature con ante rientranti per celare tutto ciò che è necessario per consumare un pasto durante una breve pausa. Una proposta dal design essenziale, che vanta numerose finiture e un'ampia gamma di materiali, ideale per progettare soluzioni modulabili e personalizzate.

---

Kitchen areas in a forward-looking office.

Eidos Evo collection offers modular elements to also furnish the dedicated relaxation areas such as round tables, tall cabinets with pocket door sliding systems to hide all that you need to enjoy meals on short breaks. A proposal with an essential design, which boasts many finishes and a wide range of materials, ideal for designing modular and customized solutions.

Àreas de comedor en una oficina que mira hacia el futuro.

La colección Eidos Evo ofrece elementos modulables ideales para decorar también los espacios dedicados al relax como las mesas redondas, las columnas con puerta escamoteables para ocultar todo lo necesario para preparar una comida durante un breve descanso. Una propuesta de diseño esencial, que ofrece numerosos acabados y una amplia gama de materiales, ideales para diseñar soluciones modulables y personalizadas.

Les espaces cuisines dans le bureau qui est tourné vers l'avenir.

La collection Eidos Evo propose des éléments modulables idéaux pour meubler aussi les espaces dédiés à la détente comme les tables rondes, colonnes avec portes escamotables pour cacher tout ce qu'il faut pour prendre un repas pendant une courte pause. Une proposition au design essentiel, qui dispose de nombreuses finitions et une large gamme de matériaux, idéal pour concevoir des solutions modulables et personnalisées.











EIDOS *pro*

# TECHNICALS



Scrivanie con piani e gambe in legno  
 Desks with wooden tops and structures  
 Mesa con sobres y patas en melamina  
 Bureaux avec plateaux et pieds panneaux en mélamine

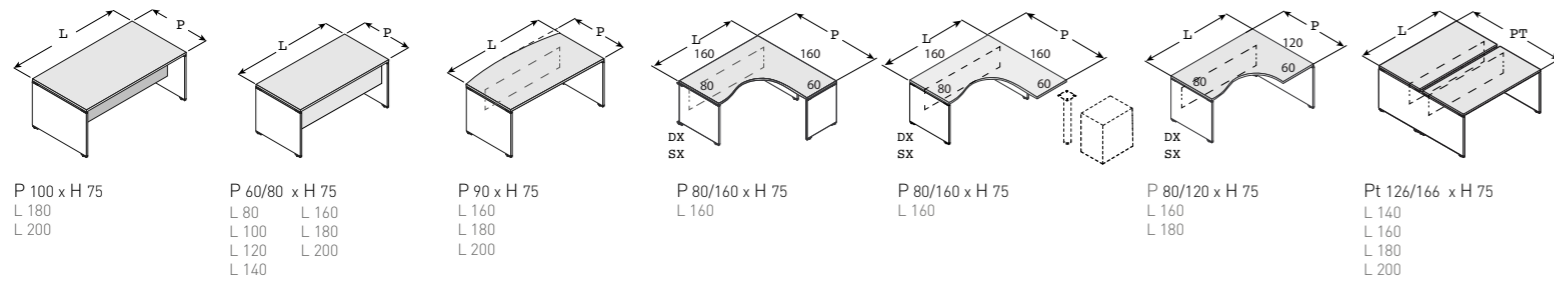

Scrivanie con piani in legno e gambe in metallo fisse  
 Desks with melamine tops and fixed metal legs  
 Mesas con sobres de melamina y patas metálicas  
 Bureaux avec plateaux en mélamine et pieds métalliques fixes

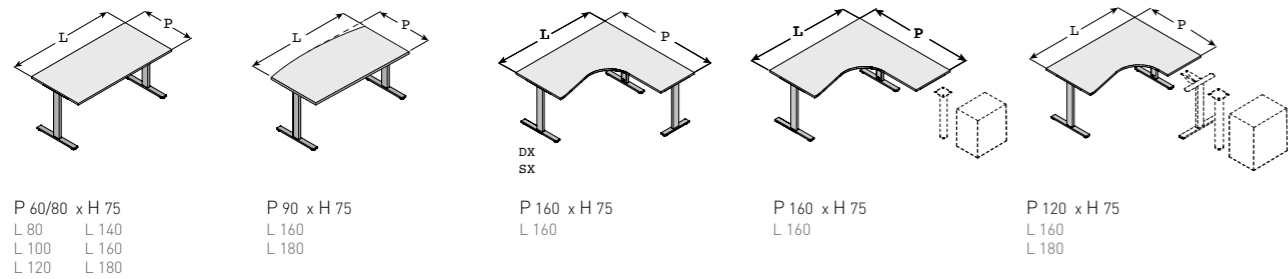

Appendici per scrivanie con gambe in legno.  
 Desk extension with melamine paneled leg  
 Alas auxiliares para mesas con patas en melamina  
 Retour pour bureaux pieds panneaux en mélamine

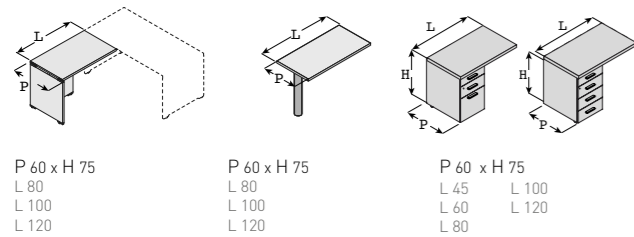

Appendici per scrivanie con gambe in metallo fisse.  
 Extensions for desks with fixed metal legs  
 Alas auxiliares para mesas con patas metálicas  
 Retour pour bureaux avec pieds métalliques fixes

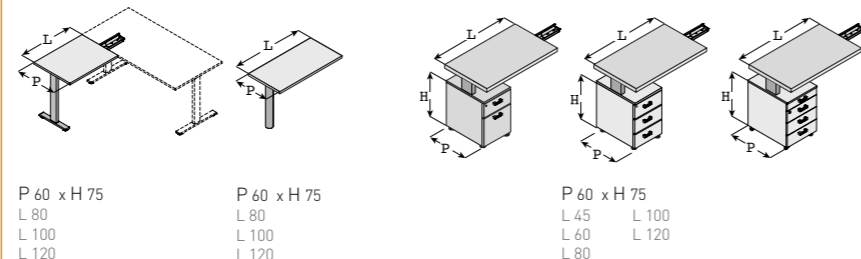

Scrivanie con piani in legno e gambe in metallo selezionabili  
 Desks with melamine tops and selectable metal legs  
 Mesas con sobres de melamina y patas metálicas ajustables  
 Bureaux avec plateaux en mélamine et pieds métalliques réglables par vis

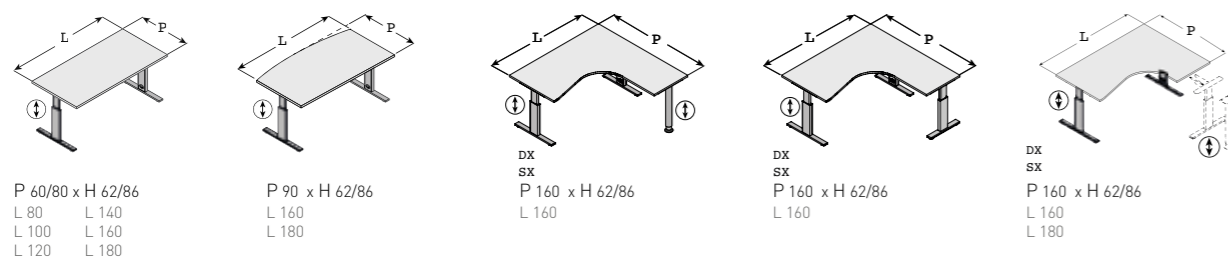

Appendici per scrivanie con gambe in metallo selezionabili.  
 Extensions for desks with melamine tops and selectable metal legs  
 Alas auxiliares para mesas con patas metálicas ajustables  
 Retour pour bureaux avec pieds métalliques réglables par vis

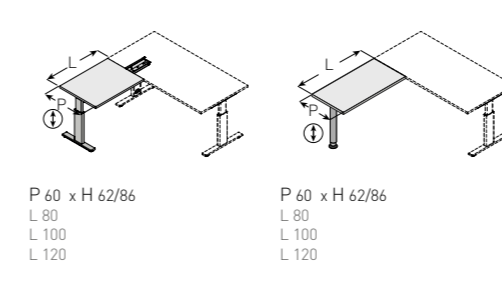

Tavolo ribaltabile e Accessori  
 Folding table and accessories  
 Mesa con tapa abatible y accesorios  
 Table abattante et accessoires

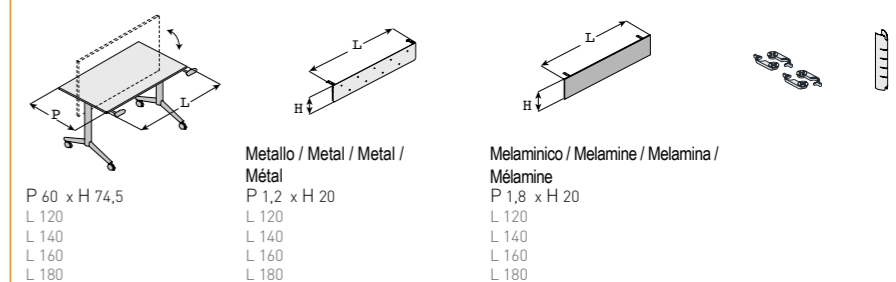

Scrivanie con piani in legno e gambe in metallo elevabili elettricamente  
 Desk with melamine tops and metal legs electrically adjustable  
 Mesa con sobres de melamina y patas metálicas regulables en altura eléctricamente  
 Bureaux avec plateaux en mélamine et pieds métalliques réglables électriques

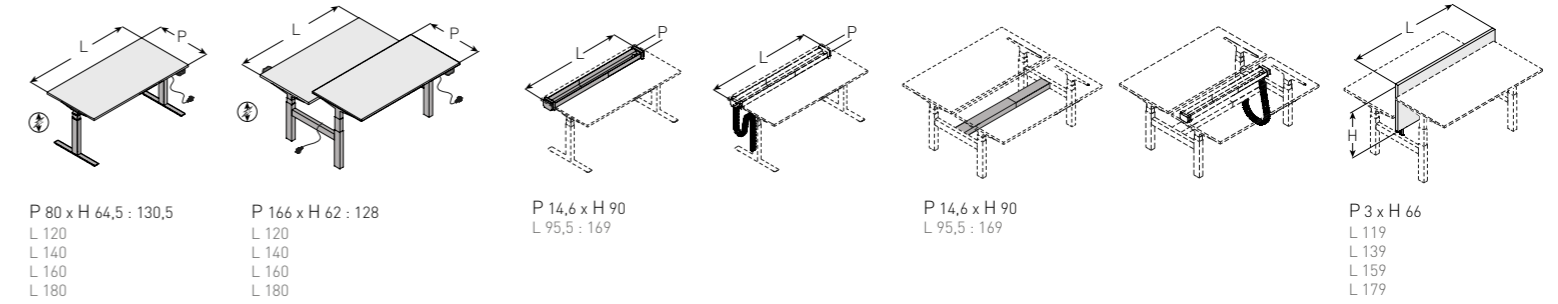

Schermi frontali melaminici o rivestiti, totali e parziali  
 Frontal screens, melamine or fabric, full or partial  
 Separadores frontales en melamina o tapizado, longitud total y parcial  
 Ecrans frontaux mélamine ou tissu, partiels ou toute longueur

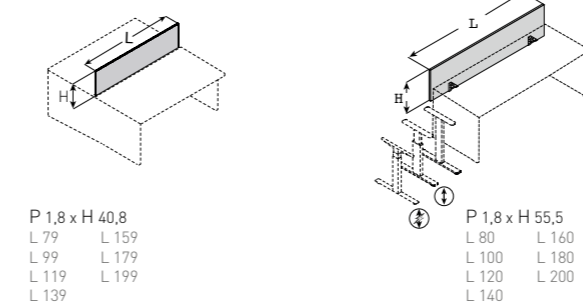

Schermi laterali melaminici o rivestiti  
 Side melamine or fabric screens  
 Separadores laterales en melamina o tapizado  
 Ecrans latéraux mélamine ou tissu.

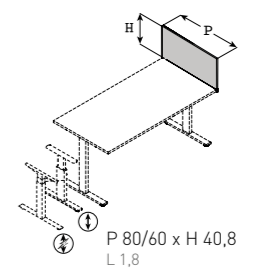

Schermi frontali fonoassorbenti totali e parziali  
 Sound proof screens, full or partial  
 Separadores frontales fonoabsorbentes, longitud total y parcial  
 Ecrans frontaux phoniques partiels ou toute longueur

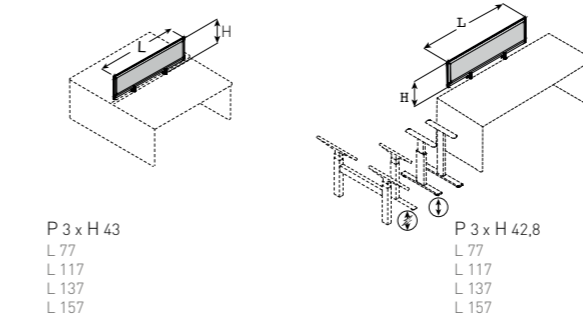

Gonna  
 Modesty panel  
 Faldones  
 Voile de fond

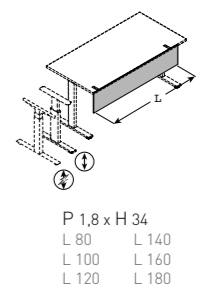

Canalizzazioni e complementi  
Cable management systems and accessories  
Canalizaciones y complementos  
Câblage et accessoires

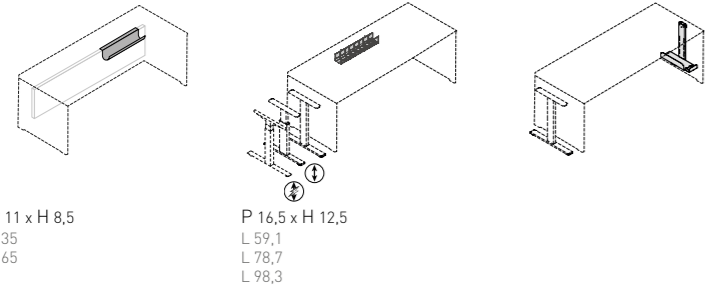

P 11 x H 8,5  
L 35  
L 65

P 16,5 x H 12,5  
L 59,1  
L 78,7  
L 98,3

Angoli di raccordo  
Junction angles  
Ángulos de unión  
Angles de jonction

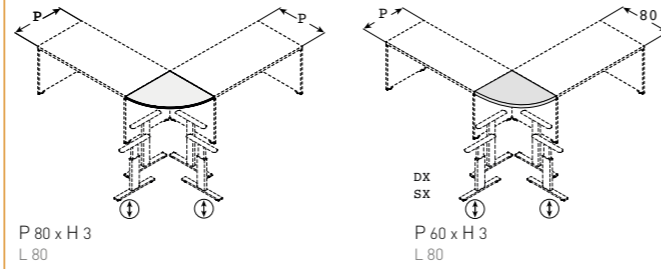

P 80 x H 3  
L 80

P 60 x H 3  
L 80

Appendici complanari  
Complanar extensions  
Extensiones complanares  
Retours

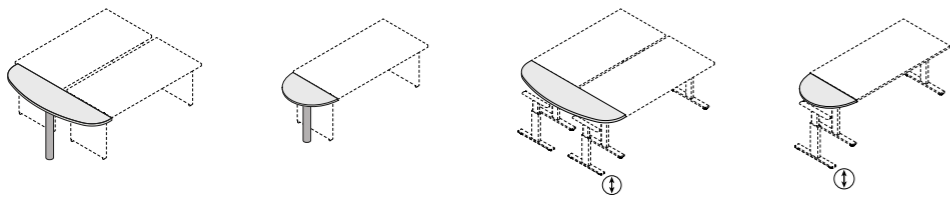

P 45 x H 74,4  
L 126  
L 166

P 40 x H 74,4  
L 80

P 45 x H 3  
L 126  
L 166

P 40 x H 3  
L 80

Tavoli riunione  
Meeting tables  
Mesas de juntas  
Tables réunion

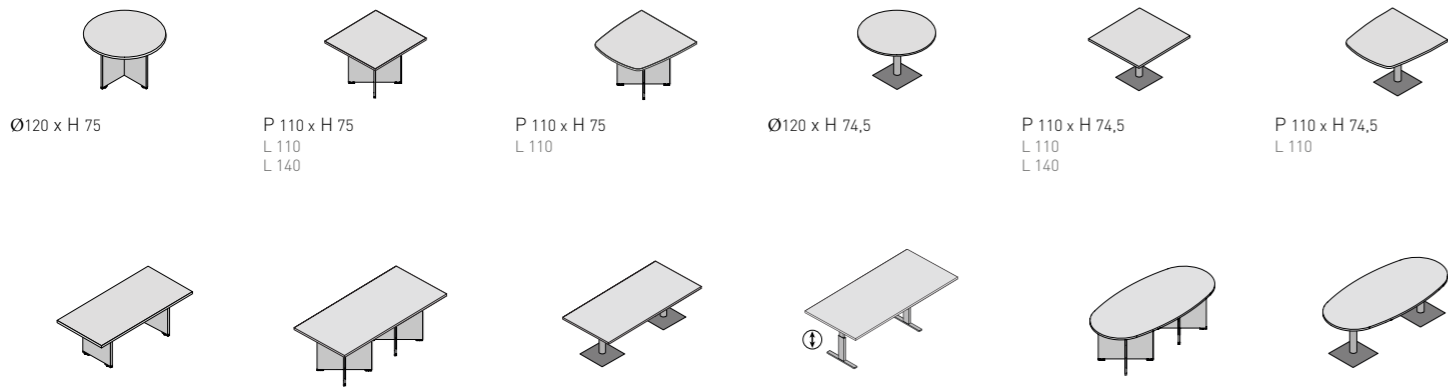

Ø120 x H 75

P 110 x H 75  
L 110  
L 140

P 110 x H 75  
L 110

Ø120 x H 74,5

P 110 x H 74,5  
L 110  
L 140

P 110 x H 74,5  
L 110

P 110 x H 75  
L 220  
L 250

P 110 x H 75  
L 220  
L 250

P 110 x H 74,5  
L 220  
L 250

P 110 x H 75  
L 220  
L 250

P 110 x H 75  
L 220

P 110 x H 75  
L 220  
L 250

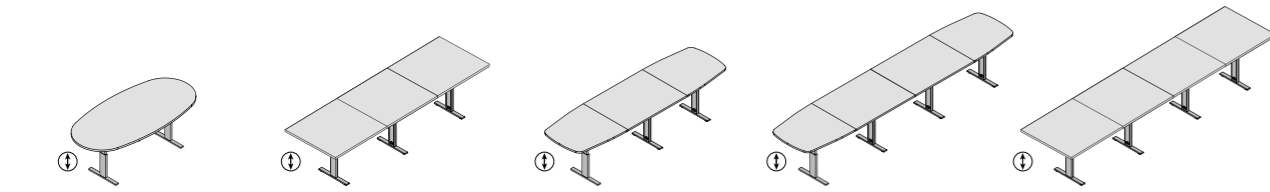

P 110 x H 75  
L 220

P 110 x H 75  
L 360

P 110 x H 75  
L 360

P 110 x H 75  
L 500

P 110 x H 75  
L 500

Paretine  
Partitions  
Separadores a suelo  
Cloisons

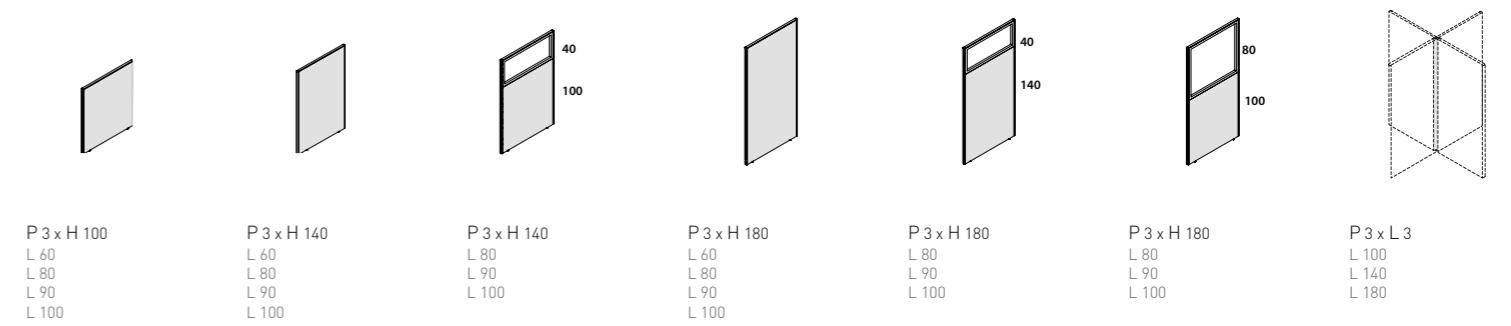

P 3 x H 100  
L 60  
L 80  
L 90  
L 100

P 3 x H 140  
L 60  
L 80  
L 90  
L 100

P 3 x H 140  
L 80  
L 90  
L 100

P 3 x H 180  
L 60  
L 80  
L 90  
L 100

P 3 x H 180  
L 80  
L 90  
L 100

P 3 x H 180  
L 80  
L 90  
L 100

P 3 x L 3  
L 100  
L 140  
L 180

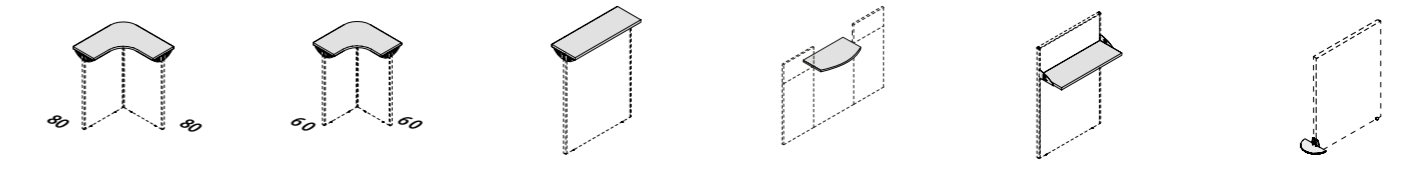

P 32 x H 3  
L 97,5x97,5

P 32 x H 3  
L 77,5x77,5

P 32 x H 3  
L 80 L 140  
L 90 L 160  
L 100 L 180  
L 120 L 200

P 45 x H 3  
L 60  
L 80  
L 90  
L 100

P 32 x H 3  
L 60  
L 80  
L 90  
L 100

P 25 x H 8  
L 12

Cassettiere e mobile di servizio  
Pedestal and Service cabinet  
Cajonera y Mueble auxiliar  
Caisson et Meuble de service

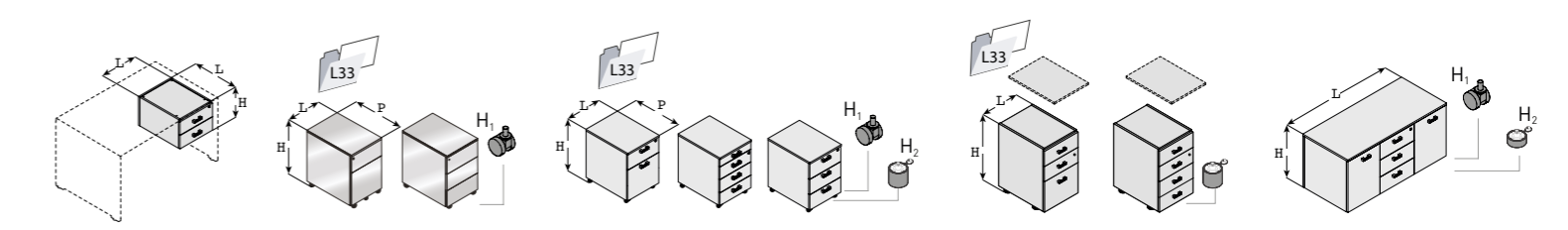

P 52,5 x H 31,5  
L 42

P 53,5 x H 55,5  
L 42

P 56 x H1/ H2 60  
L 42

P 60 x H 72  
L 42,5

P 55 x H+H1=58; H+H2= 60,5  
L 120

Lockers  
Lockers  
Taquillas  
Casier

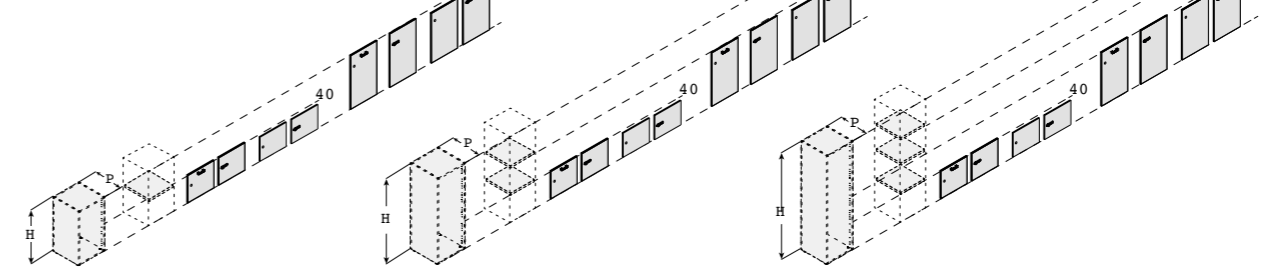

P 46 x H 81,7  
L 45

P 46 x H 121,7  
L 45

P 46 x H 161,7  
L 45

Accessori per Lockers  
Lockers accessories  
Accesorios para taquillas  
Accessories pour casiers

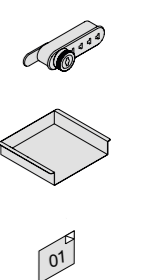

Librerie Bookcases Librerías Armoires	Ante melaminico Melamine doors Puertas en melamina Portes en mélamine	Ante vetro fumè Smoked glass doors Puertas en vidrio fumè Portes en verre fumè	Ante vetro acidato telaio alluminio Aluminium framed etched glass doors Puertas de vidrio ácido con marco de aluminio Portes en verre dépoli châssis aluminium apparent
--	--	---	--

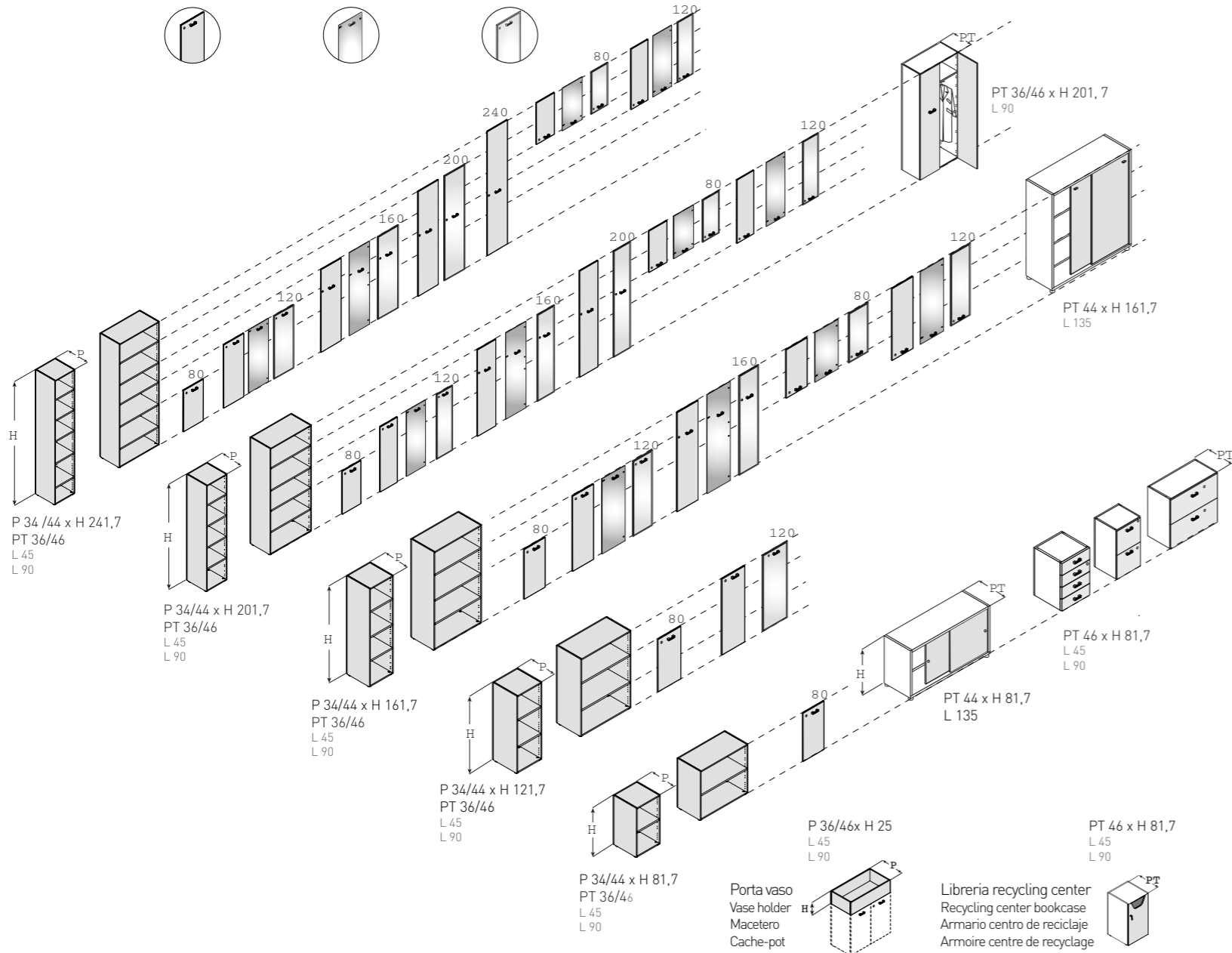

EIDOS *pro*

# FINISHES

Top modulare Modular top Tapa modular Top modulaire	Fianchi di finitura Finishing side panels Costados finales Côtés finaux armoire	Pensili Wall units Colgantes Meubles suspendus
--	--	---

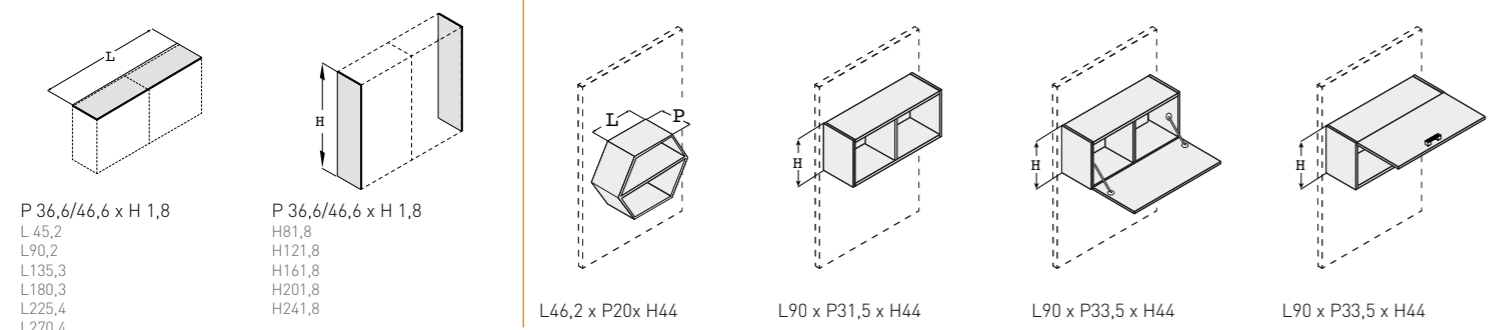

**Piani in legno /** Melamine tops / Sobres en melamina / Plateaux en mélamine

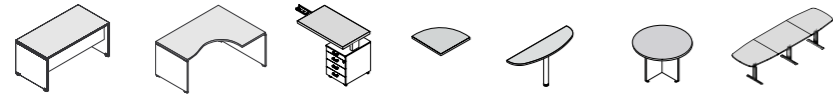

Melaminico / Melamine / Melamina / Mélamine



GC\* Grigio Cosmico BT Bianco Seta GA Grigio avorio N2 Noce Corteccia

**Fianchi in legno /** Wooden legs / Costados en melamina / Pieds panneaux

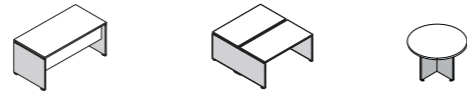

Melaminico / Melamine / Melamina / Mélamine

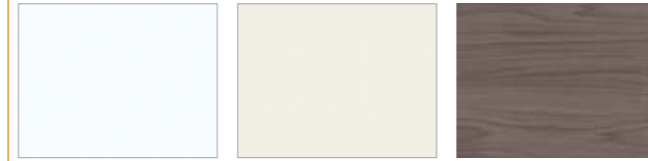

BT Bianco Seta GA Grigio avorio N2 Noce Corteccia

**Gambe metallo fisse e regolabili /** Metal legs / Patas metálicas / Pieds métalliques

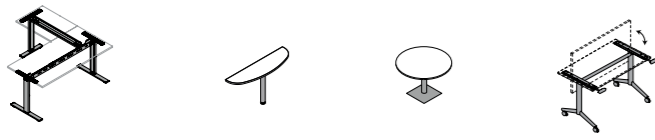

Metallo / Metal / Metal / Métal

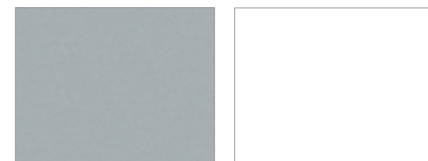

AL Alluminio BI Bianco

**Strutture in metallo elevabili elettricamente /** Metal structures electrically adjustable / Estructuras metálicas regulables en altura eléctricamente / Structures métalliques réglables électriques

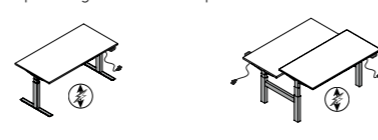

Metallo / Metal / Metal / Métal



NE Nero BI Bianco

**Cassa e top /** Structure and top / Estructura y tapa / Coffre et top

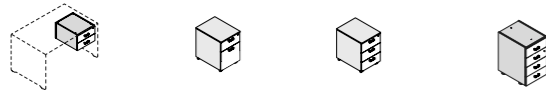

Melaminico / Melamine / Melamina / Mélamine

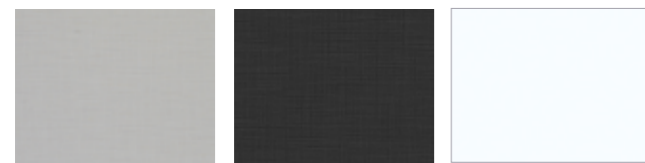

94 Alcene AA Alcene Antracite BT Bianco Seta

**Frontali /** Frontals / Frontales / Façade



Melaminico / Melamine / Melamina / Mélamine

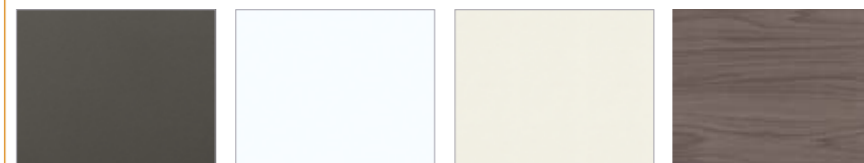

GC Grigio Cosmico BT Bianco Seta GA Grigio avorio N2 Noce Corteccia

**Top e frontali /** Top and frontals / Tapa y frontales / Top et façades

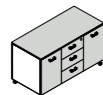

Melaminico / Melamine / Melamina / Mélamine



GC Grigio Cosmico BT Bianco Seta GA Grigio avorio N2 Noce Corteccia

**Cassettiere in metallo /** Metal pedestals / Cajoneras metálicas / Caissons métalliques



Melaminico / Melamine / Melamina / Mélamine

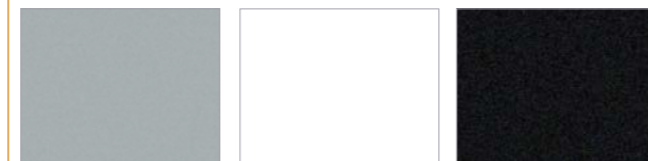

AL Alluminio BI Bianco NE Nero

\* Bordo effetto multistrato solo per sp.30 mm / Multilayer effect edge only for thick.30 mm / Chant effet multiplis uniquement pour épaisseur 30mm / Borde de efecto multicapa solo para espesor 30 mm

**Traverse e Gonne /** Regular and structural modesty panels / Travesaños y faldones / Voiles de fond

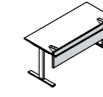

Melaminico / Melamine / Melamina / Mélamine



GC Grigio Cosmico BT Bianco Seta GA Grigio avorio N2 Noce Corteccia

**Canalizzazioni e complementi /** Cable management systems and accessories / Canalizaciones y complementos / Câblage et accessoires



Metallo / Metal / Metal / Métal

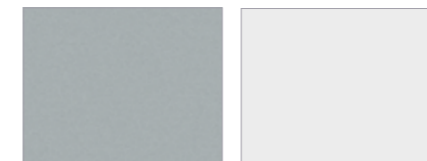

AL Alluminio ZI Zincato

Metallo / Metal / Metal / Métal



AL Alluminio BI Bianco

**Schermi in melaminico /** Melamine screens / Separadores en melamina / Ecrans mélamine

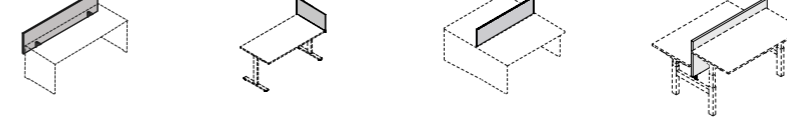

Melaminico / Melamine / Melamina / Mélamine

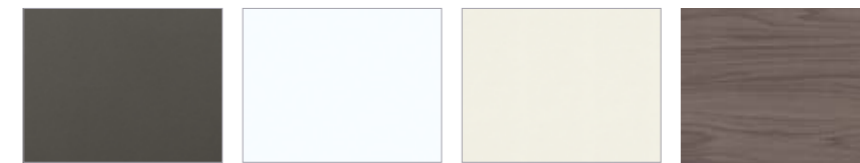

GC Grigio Cosmico BT Bianco Seta GA Grigio avorio N2 Noce Corteccia

**Schermi in tessuto /** Fabric screens / Separadores tapizados / Ecrans tissu  
**Schermi Fonoassorbenti /** Acoustic screens / Separadores fonoabsorbentes / Ecrans acoustiques

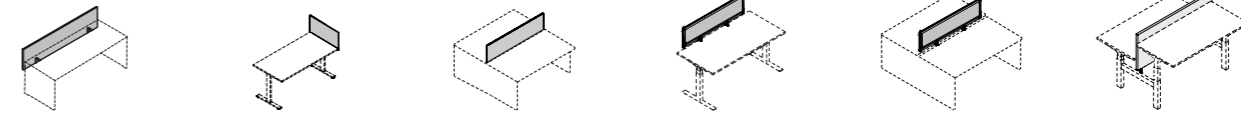

Tessuto / Fabric / Tela / Tissu

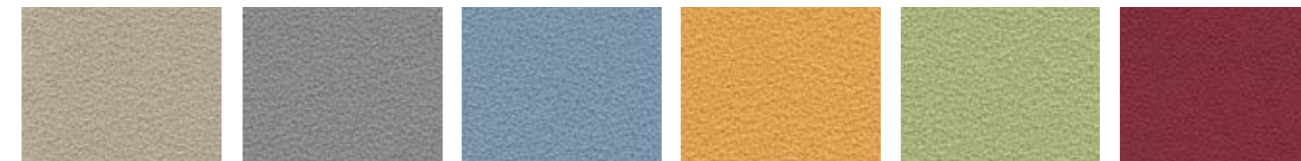

AV Avorio GR Grigio AZ Azzurro GI Giallo VE Verde RO Rosso

**Paretine / Partitions / Separadores a suelo / Cloisons**

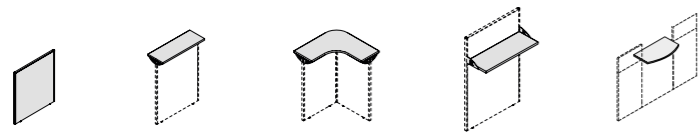

**Melaminico / Melamine / Melamina / Mélamine**



**GC\*** Grigio Cosmico    **BT** Bianco Seta    **GA** Grigio avorio    **N2** Noce Corteccia

**Paretine / Partitions / Separadores a suelo / Cloisons**



**Metallo / Metal / Metal / Métal**



**AL** Alluminio    **BI** Bianco

**Vetro / Glass / Cristal / Verre**



**TR** Trasparente

**Librerie / Bookcases / Librerías / Armoires**

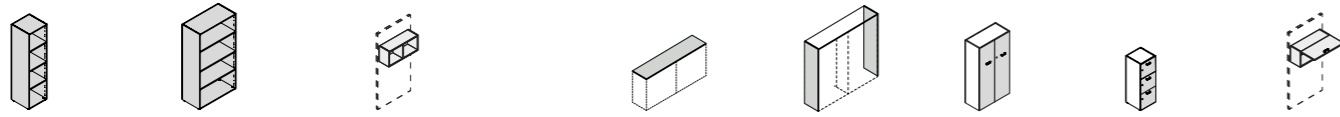

**Melaminico / Melamine / Melamina / Mélamine**



**94** Alcene    **AA** Alcene Antracite    **BT** Bianco Seta    **GC** Grigio Cosmico    **BT** Bianco Seta    **GA** Grigio avorio    **N2** Noce Corteccia

**Librerie / Bookcases / Librerías / Armoires**

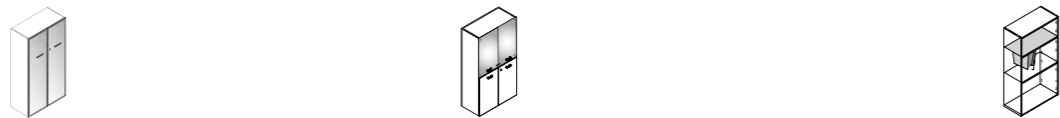

**Vetro / Glass / Cristal / Verre**

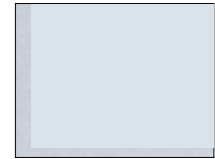

**VA** Vetro Acidato

**Vetro / Glass / Cristal / Verre**



**VF** Vetro Fumè

**Metallo / Metal / Metal / Métal**

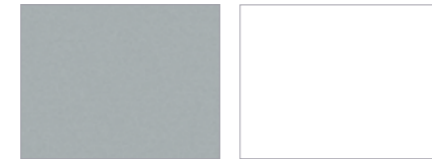

**AL** Alluminio    **BI** Bianco

\* **Bordo effetto multistrato solo per sp.30 mm / Multilayer effect edge only for thick.30 mm / Chant effet multiplis uniquement pour épaisseur 30mm / Borde de efecto multicapa solo para espesor 30 mm**

Art Director:  
Ulisse Narcisi  
Image:  
Nerokubo  
Fotolito e stampa:

ARANWORLD SRL U. NEL PERSEGUIRE UNA POLITICA VOLTA AL COSTANTE MIGLIORAMENTO, SI RISERVA IL DIRITTO DI APPORTARE, IN QUALSIASI MOMENTO E SENZA PREAVVISO, LE MODIFICHE AI PRODOTTI CHE RITERRA UTILI E NECESSARIE. L'EFFETTIVA DISPONIBILITÀ DI QUANTO A CATALOGO DEV'ESSERE EFFETTIVAMENTE VERIFICATA AL MOMENTO DELL'ORDINE. A CAUSA DI NATURALI LIMITI TECNICI DI RIPRODUZIONE E STAMPA, IL COLORE DEI MODELLI A CATALOGO È PURAMENTE INDICATIVO E NON PUÒ COSTITUIRE MOTIVO DI RIVALSA. ARANWORLD S.R.L. U. ASSECONDANDO LA PROPRIA VOCAZIONE ECOLOGISTA, HA ADOTTATO IL FONT CALIBRI AL FINE DI CONTRIBUIRE ULTERIORMENTE A SALVAGUARDARE IL NOSTRO PIANETA GRAZIE AL RIDOTTO CONSUMO DI TONER E CARTA GRAZIE A QUESTO ACCORGIMENTO.

THE COMPANY ACTIVELY PURSUES AN AMBITIOUS CONTINUOUS IMPROVEMENT POLICY AND IT RESERVES THE RIGHT TO MAKE AT ANY TIME AND WITHOUT PRIOR NOTICE THE CHANGES IN THE PRODUCT AS IT DEEMS USEFUL AND NECESSARY. THE ACTUAL AVAILABILITY OF THE ITEMS SHOWN IN THE CATALOGUE MUST BE VERIFIED AT THE TIME OF THE ORDER. DUE TO TECHNICAL LIMITATIONS IN NATURAL REPRODUCTION AND PRINTING, THE COLOUR OF THE MODELS IN THE CATALOGUE ARE PURELY INDICATIVE AND CANNOT BE A REASON FOR RECOURSE. THE COMPANY, FAVORING ITS ECOLOGICAL VOCATION, HAS ADOPTED THE CALIBRI FONT IN ORDER TO FURTHER CONTRIBUTE TO SAFEGUARD OUR PLANET IN REDUCING CONSUMPTION OF PAPER AND TONER THANKS TO THIS DEVICE.

ARANWORLD SRL U., PERSIGUIENDO UNA POLÍTICA DESTINADA A UNA CONSTANTE MEJORA, SE RESERVA EL DERECHO DE APORTAR, EN CUALQUIER MOMENTO Y SIN PREAVISO, LAS MODIFICACIONES A LOS PRODUCTOS QUE CONSIDERARÁ ÚTILES Y NECESARIAS. LA EFECTIVA DISPONIBILIDAD DE LO INDICADO EN EL PRESENTE CATÁLOGO DEBE EFECTIVAMENTE COMPROBARSE AL MOMENTO DE REALIZAR EL PEDIDO. DEBIDO A NATURALES LÍMITES TÉCNICOS DE REPRODUCCIÓN E IMPRESIÓN, EL COLOR DE LOS MODELOS DEL CATÁLOGO ES PURAMENTE INDICATIVO Y NO PUEDE CONSTITUIR UN MOTIVO DE INDEMNIZACIÓN. ARANWORLD S.R.L. U., SIGUIENDO SU PROPIA VOCACIÓN ECOLÓGICA, HA ADOPTADO EL FONT CALIBRI CON EL FIN DE AYUDAR ULTERIORMENTE A PROTEGER NUESTRO PLANETA, GRACIAS A LA REDUCCIÓN DEL CONSUMO DE TÓNER Y DE PAPEL, GRACIAS A ESTE RECURSO.

ARANWORLD SRL U. POUR POURSUIVRE UNE POLITIQUE VERS LA CONSTANT AMÉLIORATION, SE RÉSERVE LE DROIT D'APPORTER, N'IMPORTE QUAND ET SANS PRÉAVIS, LES MODIFICATIONS RETENUES UTILES ET NÉCESSAIRES. L'EFFECTIVE DISPONIBILITÉ DES ARTICLES DU CATALOGUE SERA OBJET DE VÉRIFICATION LORS DE LA COMMANDE. A' CAUSE DES LIMITES TECHNIQUES DE REPRODUCTION ET IMPRESSION, LES COLORIS DE LA GAMME ET DU CATALOGUES SONT INDICATIVES ET NE PEUVENT PAS FAIRE OBJET DE RÉCLAMATION. ARANWORLD S.R.L. U. DANS LA CIBLE DE RESPECTER SA VOCATION ÉCOLOGISTE, A UTILISÉ LE FONT CALIBRI POUR CONTRIBUER À SAUVEGARDER L'ENVIRONNEMENT DE LA PLANÈTE GRÂCE À LA RÉDUITE CONSOMMATION DE TONER ET PAPIER QUE CETTE CHOIX AMÈNE.

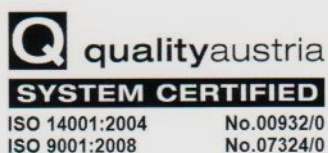

L'effettiva disponibilità di quanto a catalogo dev'essere effettivamente verificata al momento dell'ordine. A causa di naturali limiti tecnici di riproduzione e stampa, il colore dei modelli a catalogo è puramente indicativo e non può costituire motivo di rivalsa. Aran World S.r.l.U., assecondando la propria vocazione ecologista, ha adottato il font Calibri al fine di contribuire ulteriormente a salvaguardare il nostro pianeta grazie al ridotto consumo di toner e carta.

The company actively pursues an ambitious continuous improvement policy and it reserves the right to make at any time and without prior notice the changes in the product as it deems useful and necessary. The actual availability of the items shown in the catalogue must be verified at the time of the order. Due to technical limitations in natural reproduction and printing, the colour of the models in the catalogue are purely indicative and cannot be a reason for recourse. Aran World S.r.l.U., favoring its ecological vocation, has adopted the Calibri font in order to further contribute to safeguard our planet in reducing consumption of paper and toner thanks to this device.

Aran World S.r.l.U., persiguiendo una política destinada a una constante mejora, se reserva el derecho de aportar, en cualquier momento y sin preaviso, las modificaciones a los productos que considerará útiles y necesarias. La efectiva disponibilidad de lo indicado en el presente catálogo debe efectivamente comprobarse al momento de realizar el pedido. Debido a naturales límites técnicos de reproducción e impresión, el color de los modelos del catálogo es puramente indicativo y no puede constituir un motivo de indemnización. Aran World S.r.l.U., siguiendo su propia vocación ecológica, ha adoptado el font Calibri con el fin de ayudar ulteriormente a proteger nuestro planeta, gracias a la reducción del consumo de tóner y de papel.

Aran World S.r.l.U. pour poursuivre une politique vers la constant amélioration, se réserve le droit d'apporter, n'importe quand et sans préavis, les modifications retenues utiles et nécessaires. L'effective disponibilité des articles du catalogue sera objet de vérification lors de la commande. A' cause des limites techniques de reproduction et impression, les coloris de la gamme et du catalogues sont indicatives et ne peuvent pas faire objet de réclamation. Aran World S.r.l.U., dans la cible de respecter sa vocation écologiste, a utilisé le font Calibri pour contribuer à sauvegarder l'environnement de la planète grâce à la réduite consommation de toner et papier que cette choix amène.